



2021 Maryland Wood Bridge Challenge Contest Rules

For regional competition information, please contact the head engineer, Michael Newman, at conradnewman13@gmail.com or the Baltimore Museum of Industry (BMI) coordinator, Jessica Celmer, at jcelmer@thebmi.org. Additional information and discussion is available on the Maryland Engineering Challenges Discord forum (invitation link can be provided by request).

If there is to be a multi-regional competition after the Maryland Engineering Competition, a high school or middle school student must have placed first or second in this Regional Contest to compete. Group submissions at the Maryland regional competition are allowed to compete at the national level for 2021.

The object of this contest is to see who can design, construct and test the **most efficient** bridge within the specifications. Model bridges are intended to be simplified versions of real-world bridges, which are designed to permit a load to travel across the entire bridge. In order to simplify the model bridge design process, the number of loading positions is reduced, and to allow the contest to proceed in a reasonable amount of time, only one loading position is actually tested. These simplifications do not negate the requirement that the bridge must be designed to accept a load at any of the positions. Bridges determined by the judges to not meet this requirement will be disqualified and tested as unofficial bridges.

Note: Section 5.2 is the most impactful and complicated addition to the rule set. It is intended to better facilitate a remote competition and avoid disqualification of mailed-in bridges.

1. Materials

1. The bridge must be constructed only from 3/32-inch square cross-section basswood and any commonly available adhesive.
2. The official basswood may be notched, cut, sanded or laminated in any manner but must still be identifiable as the original official basswood.
3. No other materials may be used. The bridge may not be stained, painted or coated in any fashion with any foreign substance.

2. Construction

1. The bridge mass shall be no greater than 25.00 grams.
2. The bridge (see auxiliary figure) must span a gap (**S**) of 300. mm, be no shorter than 305. mm or longer (**L**) than 400. mm, be no taller (**H**) than 80. mm above the support surface, and no wider (**W**) than 80. mm at the loading surface. The bridge structure may project a maximum of (**B**) of 20. mm below the support surfaces (see Figure 1). The structure may not interact with the vertical faces of the support surfaces.

3. The bridge must be constructed to provide a horizontal support for the load at each of the two possible loading locations (see 3.3). Any portion of the structure above the loading plane must provide clearance for the loading plate and for the eyebolt (see 3.2).
4. The loading plane (**P**) shall be between 0. and 15. mm above the support surface. The plane height shall be the same for both locations.
5. The bridge must be symmetrical about the midpoint of the span.

3. Loading

1. On the day of the competition, the judges will load one of the two loading locations (arbitrary due to symmetry). Competition loading will stop at 50. kg, loading will continue until bridge failure (see 4.4)
2. The load will be applied by means of a 40. mm square plate (see Figure 1) with a thickness (**t**) of 10 mm. A 9.53 mm (3/8 inch) diameter eyebolt is attached from below to the center of the plate and extends beyond 100 mm above the supports. The plate will be horizontal and will be mounted with two edges parallel to the longitudinal axis of the bridge.
3. The load will be applied with the center of the plate at one of two (2) possible loading locations on the longitudinal axis of the bridge: 20. mm to the right and left of center of the span. The 2 loading locations must lie in the same horizontal loading plane (**P**) between 0. and 15. mm above the support surface.

4. Testing

1. On the day of the competition, the bridge will be centered on the support surfaces.
2. The loading plate will be lowered from above on the bridge at the selected loading location with two edges of the plate parallel to the longitudinal axis of the bridge.
3. The load will be applied from below, as described in Section 3 above. Competition loading will stop at 50. kg. However, loading will continue until bridge failure (see 4.4).
4. Bridge failure is defined as the inability of the bridge to carry additional load, or a load deflection of 25. mm under the loading location, whichever occurs first.
5. The bridge with the highest structural efficiency, *E*, will be declared the winner. Bridges failing above 50. kg will be considered to have held 50. kg for efficiency calculation. See 5.2 for definition of *X*.

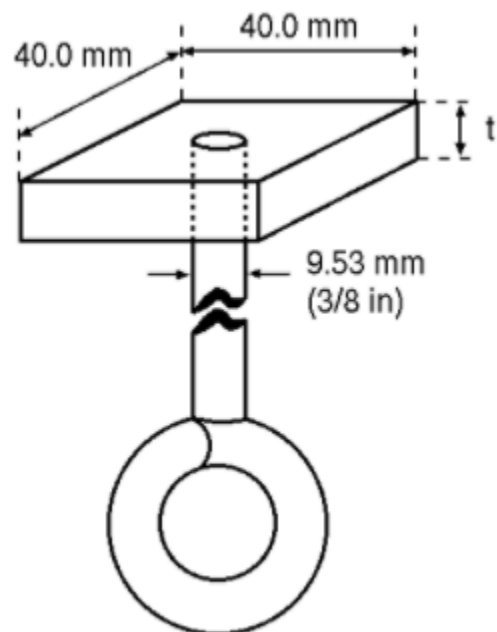

Figure 1. Loading Plate Detail

$E = \text{Load supported in grams (50,000g maximum)} * (100\% - 1\% * X) / \text{Mass of bridge in grams}$

5. Qualification

1. All construction and material requirements will be checked prior to testing. Bridges failing to meet these requirements or associated tolerances (see **5.2**) will be disqualified. If physically possible, disqualified bridges may be tested as exhibition bridges at the discretion of the builder and the contest directors.
2. Portions of Section 2 will have a tolerance zone of 5. mm surrounding the disqualification values provided. Within this area, 2% of the bridge's Maximum Supported Load will be deducted for each millimeter outside of a provided specification. Bridges outside of the 5. mm tolerance will be disqualified (see **5.1**). Penalties for all violations will be summed and the total penalty percentage (X) will be reduced from E as prescribed in **4.5**.
3. If, during testing, a condition becomes apparent (i.e., use of ineligible materials, inability to support the loading plate, etc.) which is a violation of the rules or prevents testing as described above in Section 4, that bridge shall be disqualified. Bridges found to be optimized for one loading location will be tested at the weaker of the two loading locations.
4. Day-of qualification decisions of the judges are final. These rules may be revised as experience shows the need. Please check our website, <https://www.thebmi.org/visit/maryland-engineering-challenges/> after November 30, 2020, to learn whether any changes have been made and confirm the final draft of these rules.

