

Maryland Engineering Challenges

2019 Straw Bridge Challenge

Middle School Level – Grades 6 to 8

Supported

By:

American Society of Mechanical Engineers, Baltimore Section

Engineer Contacts:

Kevin Capinpin — capinpin@usa.net

Frank Regan — franklin.regan@gmail.com

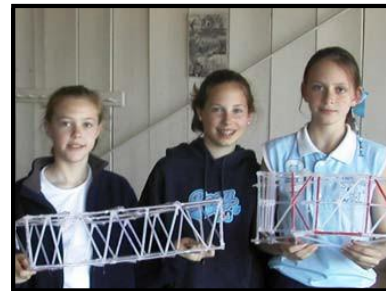

Important Dates

Coaches' Information Session

⇒ **Wednesday, November 14, 2018**

4:00 p.m. to 7:00 p.m.

This “drop-in” event is designed for adults interested in coaching a team to stop by and chat with engineers. Find out if a particular Challenge is a good fit for your students. The Information Session is not required and there is no cost. Registration is strongly encouraged. Contact James at jkeffer@thebmi.org

Coaches' Hands-On Workshop

⇒ **Saturday, January 26, 2019**

Beginning at 10:00 a.m.

Learn the practical aspects of this Challenge. Work with engineers to explore design and constructions aspects of the project. Especially helpful for first-time Coaches and/or those without an engineering background. Registration required prior to 1/24/18. Contact James at jkeffer@thebmi.org

Registration and Written Report Due

⇒ **Friday, March 1, 2019**

Prior to 4:00 p.m.

In order to be a registered team, each team must have their adult Coach do the following:

- Register online: <http://survey.constantcontact.com/survey/a07efo0c75qjlnxjrqr/start>
- AND submit the team's Written Report as a HARD COPY to the Baltimore Museum of Industry
- AND pay a \$5 Coach's Fee, details at <https://48278.blackbaudhosting.com/48278/MEC-Coach-Fee>

Straw Bridge Competition

⇒ **Saturday, March 16, 2019**

Doors open at 9:00 a.m.

Full details about the Challenge will be emailed to Coaches after the registration deadline.

Questions about Challenge specifications or judging should be sent to the Engineer Contacts:

Kevin Capinpin — capinpin@usa.net

Frank Regan — franklin.regan@gmail.com

Other questions?

James Keffer jkeffer@thebmi.org

THE CHALLENGE

Design and construct a model road bridge made exclusively from soda straws, hotmelt glue, and plastic tabs. The roadbed of the bridge must be at least 6 but no more than 7 inches wide. Additionally, the bridge must provide a vertical clearance of at least 3.5 inches. The bridge must span a 20-inch wide hazard with the only support being the 0.5 and 1 inch ledges available at 0.75 and 4.75 inches down from the level of the roadbed, as well as the vertical wall above the uppermost ledge and between the ledges. The total depth of the hazard is 9 inches. The bridge should be as light as possible while being able to support a load, represented as a model truck, weighing 6.5 pounds for one minute.

TEAM REQUIREMENTS

Recommended team size is 2 to 4 students. There is no limit to the number of teams a school may have. Teams of one are permitted.

PERFORMANCE DEMONSTRATION GUIDELINES

- Prior to load testing the bridge will be weighed, to within 1/10 of an ounce, on a postal scale.
- The bridge will be placed in the hazard and a challenge-provided cardboard “roadway” installed.
- The bridge will be load tested using an “Eighteen Wheeler” model truck that has been weighted to approximately 6.5 pounds.
- The truck will be towed onto the bridge by means of a string attached to the tractor.
- The truck must, unassisted, remain upright during the towing process.
- When the truck is stopped in the middle of the bridge the timer will be started.
- The truck will be left on the bridge for a period of one minute.
- All bridges successfully completing the one minute load test will receive a performance score based on overall weight, with the lightest bridge receiving the maximum 35 points.

DESIGN & CONSTRUCTION STANDARDS

- The bridge must conform to the specifications in this paper; however, credit and awards are also given for ingenuity and creativity.
- The bridge must hold a 6 inch wide cardboard “roadway” made from light cardboard. Challengers should not assume any strength will be provided to the bridge structure by the cardboard roadway. While instructors are encouraged to build their own hazards and roadbeds for testing, on the day of the competition the judges will provide the hazard and roadway. The roadway must not be attached to the bridge in any way.
- The bridge may have any height above the roadway and/or any descent below the

roadway. The bridge structure may not touch down between the designated support points within the hazard.

- A detailed “Straw Bridge Design Guide,” giving further information and tips, should be downloaded from www.thebmi.org

Allowed materials:

- Drinking Straws: Solo JUMBO Drinking Straws, Item #722TX-0075, 7-3/4 long by 15/64 inches diameter (available from challenge sponsors, contact Paul Borthwick at rpborthw@yahoo.com)
- Hotmelt Glue (low temp recommended)
- Plastic tabs, at the joints only (typically cut from plastic soda bottle or milk jug material)

EVALUATION STANDARDS

All Middle School competitions involve four main components: a written report, an oral report, evaluation of the design and construction of the entry, and the entry’s performance under competition conditions. An outline of what is required for each of these, and guidance on preparing for the competition, is given in the “Middle School Guide to Entry”, which should be read in connection with this document.

The challenge scoring consists of four parts:

Written Report and Drawings	30 Points
-----------------------------	-----------

The preferred format of the report is typewritten 12 point double spaced format using a standard word processor program, although points are not deducted for a hand written report. An introduction to preparing a professional report, the “Straw Bridge Written Report Guide” may be downloaded from www.thebmi.org for further information

Oral Presentation	10 Points
-------------------	-----------

Design and Fabrication	25 Points
------------------------	-----------

Performance Demonstration	35 Points
---------------------------	-----------

GOOD LUCK TO YOUR TEAM!

Reference Drawings Follow

FIGURE 1

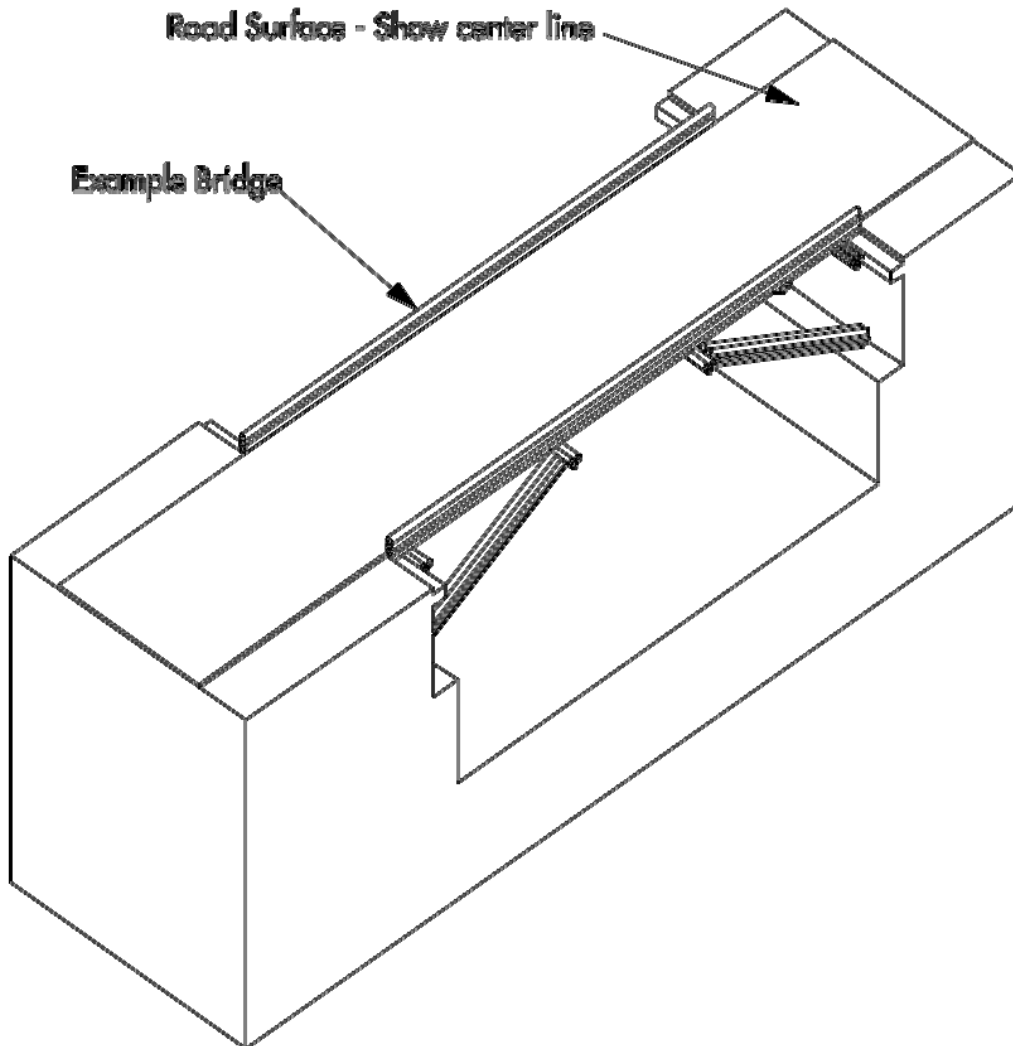

Orthogonal Sketch of Simple Bridge
Shown Over Hazard
Road bed must be at least 6" wide

FIGURE 2

Line Drawing showing the pertinent dimensions of the straw bridge hazard. (prepared by Steve Pederson, Contract Engineering Services)

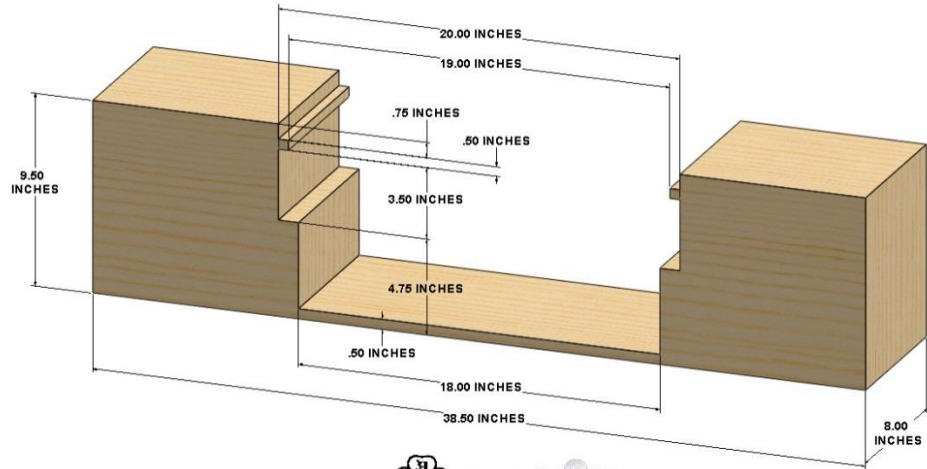

 ASME  ASME
STRAWBRIDGE HAZARD